



EBANO DE

# EBANO EcoDesign



EAN 8426964230154  
REF 23015

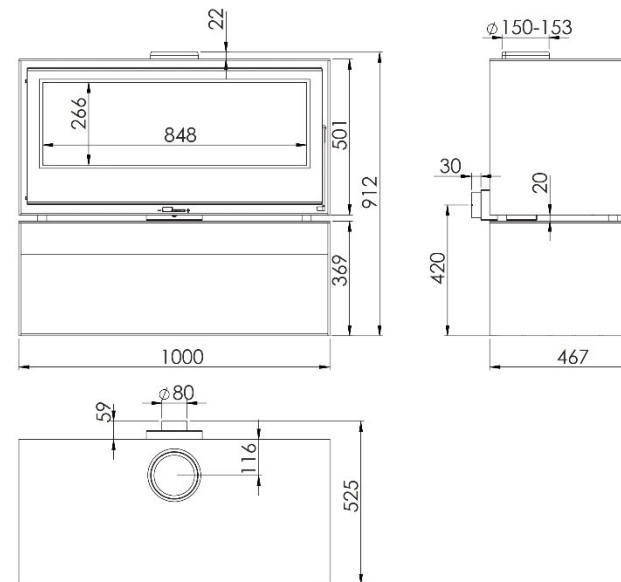

## MAßE

|   |                                 |
|---|---------------------------------|
| MAßE H x B x T                                  | <b>912x1000x525 mm</b>          |
| GEWICHT BRUTTO                                  | <b>263 kg</b>                   |
| MAßE FEUERRAUMTÜR                               | <b>848x266 mm</b>               |
| DURCHMESSER DES ABGASSTUTZEN                    | <b>Ø 150-153 mm</b><br>Vertikal |
| ABSTAND ZU ANGRENZENDEN BRENNBAREN MATERIALIEN: |                                 |
| Seitlich  | <b>20 cm</b>                    |
| Vorne   | <b>100 cm</b>                   |
| Hinten  | <b>10 cm</b>                    |

## EIGENSCHAFTEN

|                            |               |
|----------------------------|---------------|
| ROST UND TÜR AUS GUSSEISEN |               |
| PANORAMASICHT              |               |
| NENNLEISTUNG               | <b>8,9 KW</b> |
| WIRKUNGSGRAD               | <b>80,8 %</b> |
| CO - EMISSIONEN            | <b>0,10 %</b> |
| HITZESCHUTZANSTRICH        | <b>800°C</b>  |
| GLASKERAMIKSCHEIBE         | <b>750°C</b>  |
| HITZEBESTÄNDIG BIS         |               |



**EXTERNE LUFTZUFUHR**



**DOPPELBLECHGEHÄUSE**  
6 + 3 MM



**270 m<sup>3</sup>**  
RAUMHEIZVERMÖGEN



**VERMICULIT**  
AUSKLEIDUNG



**BEDRUCKTE**  
GLASKERAMIK



**SCHEITLÄNGE 80 CM**



**SCHEIBENSPÜLUNG**



**DREIFACHVERBRENNUNG**



**A+**

