



FICUS DE

FICUS STORE EcoDesign



EAN 8426964230604
REF. KUNST 23060

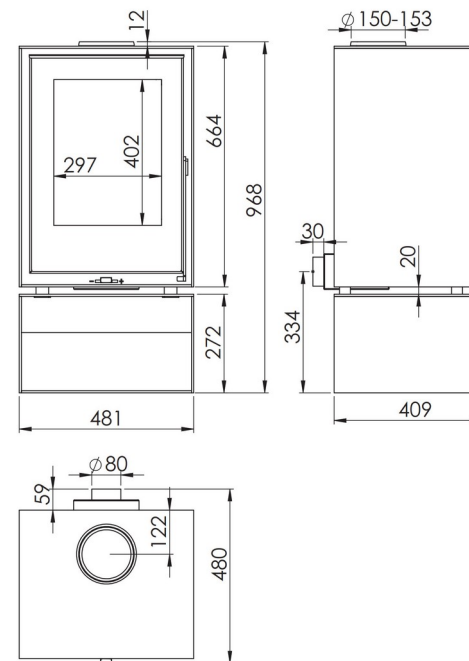

MAßE

MAßE H x B x T	968x481x480 mm
GEWICHT BRUTTO	147 kg
MAßE FEUERRAUMTÜR	297x402 mm
DURCHMESSER DES ABGASSTUTZEN	Ø 150-153 mm Vertikal
ABSTAND ZU ANGRENZENDEN BRENNBAREN MATERIALIEN:	
Seitlich	40 cm
Vorne	100 cm
Hinten	10 cm

EIGENSCHAFTEN

ROST AUS GUSSEISEN	
NENNLEISTUNG	7,5 KW
WIRKUNGSGRAD	80,7 %
CO - EMISSIONEN	0,10 %
HITZESCHUTZANSTRICH	800°C
GLASKERAMIKSCHEIBE	750°C
HITZEBESTÄNDIG BIS	



EXTERNE LUFTZUFUHR



DOPPELBLECHGEHÄUS
E 6 + 3 MM



VERMICULIT
AUSKLEIDUNG



BEDRUCKTE
GLASKERAMIK



SCHEITLÄNGE 40 CM



230
m³ RAUMHEIZVERMÖGEN



SCHEIBENSPÜLUNG



DREIFACHVERBRENNUNG



A+

