

EBANO EcoDesign



MABE

MABE H x B x T	550x1000x525 mm
GEWICHT BRUTTO	197 kg
MABE FEUERRAUMTÜR	848x266 mm
DURCHMESSER DES ABGASSTUTZEN	Ø 150-153 mm Vertikal

ABSTAND ZU ANGRENZENDEN BRENNBAREN MATERIALIEN:

Seitlich **20 cm** - Vorne **10 cm** – Hinten **100 cm**

EIGENSCHAFTEN

ROST UND TÜR AUS GUSSEISEN	
GLASKERAMIKSCHEIBE HITZEBESTÄNDIG BIS	
NENNLEISTUNG	8,9 KW
WIRKUNGSGRAD	80,8 %
CO - EMISSIONEN	0,10 %
HITZESCHUTZANSTRICH	800°C
GLASKERAMIKSCHEIBE HITZEBESTÄNDIG BIS	750°C

EAN 8426964230161
REF. KUNST 23016

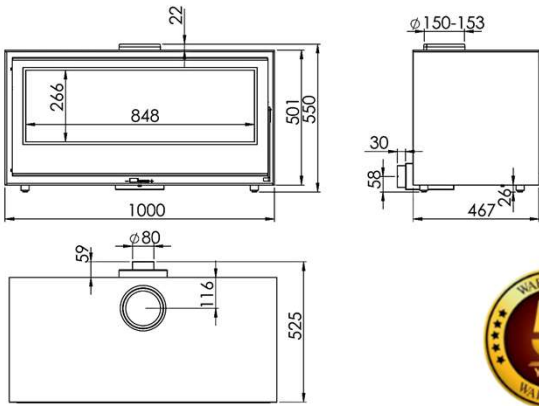

ECODESIGN



- DOPPELBLECHGEHÄUSE 6 + 3 MM
- RAUMHEIZVERMÖGEN 270 m³
- VERMICULIT AUSKLEIDUNG
- BEDRUCKTE GLASKERAMIK
- SCHEITLÄNGE 80 CM
- SCHEIBENSPÜLUNG
- DREIFACHVERBRENNUNG



Art. 15a B-VG **BImSchV2**



EBANO DE