

INSERT I-70 EcoDesign

KUNST



MAßE

| | |
|-------------------------------|--------------------------|
| MAßE H x B x T | 570x753x494 mm |
| GEWICHT BRUTTO | 105 kg |
| MAßE FEUERRAUMTÜR | 570x300 mm |
| DURCHMESSER DES ABGASSTUTZENV | Ø 150-153 mm Vertikal |

ABSTAND ZU ANGRENZENDEN BRENNBAREN MATERIALIEN:
Seitlich 80 cm - Vorne 80 cm – Hinten 80 cm

EIGENSCHAFTEN

| | |
|--|--------|
| ROST AUS GUSSEISEN | |
| NENNLEISTUNG | 7,2 KW |
| WIRKUNGSGRAD | 90,4 % |
| CO - EMISSIONEN | 0,10 % |
| HITZESCHUTZANSTRICH | 800°C |
| GLASKERAMIKSCHEIBE HITZEBESTÄNDIG BIS | 750°C |

EAN 8426964230758
REF. KUNST 23075

ECODESIGN



**EXTERNE
LUFTANSAUGUNG**



DOPPELBLECHGEHÄUSE 4 + 3 MM



VERMICULIT AUSKLEIDUNG



BEDRUCKTE GLASKERAMIK



SCHIETLÄNGE 50 CM



210 m³ RAUMHEIZVERMÖGEN



SCHEIBENSPÜLUNG



DREIFACHVERBRENNUNG



TANGENTIELLER VENTILATOR



WARMLUFT KANALISATION

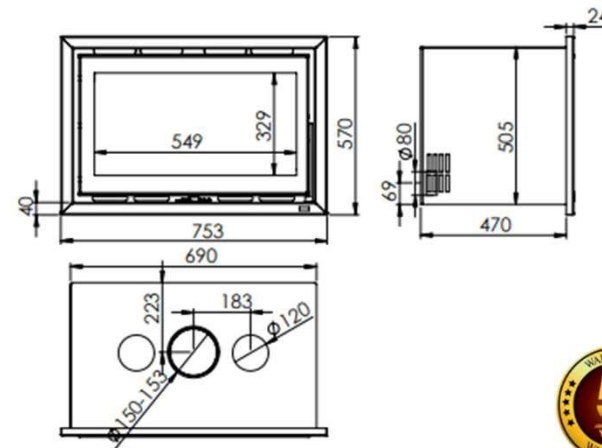

- I - VENTILATORGESCHWINDIGKEIT BEI 50%.
TEMP AKTIV > 48-50°C
- 0 - FAN OFF
- II - VENTILATORGESCHWINDIGKEIT BEI 100% IMMER
EINGESCHALTET



BImSchV2



Art. 15a B-VG

