



I-80 IT

I-80 5 Ventilato



CARATTERISTICHE

GRIGLIA IN GHISA	
POTENZA	7,6 KW
RENDIMENTO	87 %
EMISSIONI DI CO	0,05 %
VERNICE ANTICALORE RESISTENTE A	800°C
CRISTALLO IN VETROCERAMICA RESISTENTE A	750°C
DIAMETRO SCARICO FUMI	Ø 150-153 mm Verticale



PRESA D'ARIA ESTERNA



TRONCHI FINO A 50 CM



VOLUME DI RISCALDAMENTO



PORTA IN VETRO SERIGRAFATO



VERMICULITE



DOPPIO CORPO IN ACCIAIO DI 4 + 3 MM



VETRO SEMPRE PULITO



VENTILATORE TANGENZIALE



TRIPLA COMBUSTIONE



CANALIZZAZIONE D'ARIA CALDA

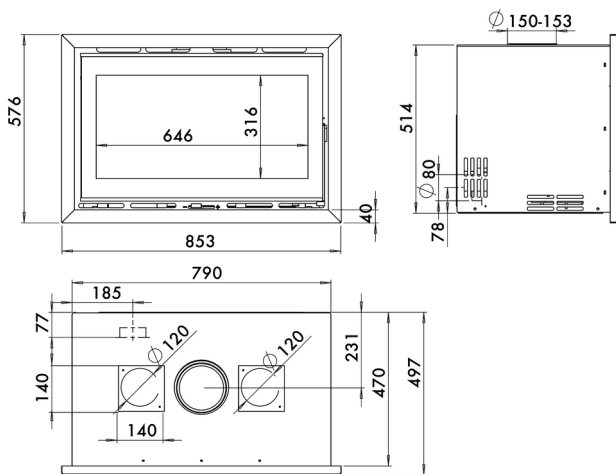

I-80 5

Ref. 33085 / EAN 8426964330854

MISURE

DIMENSIONI H X L X P	576x853x497 mm
PESO LORDO	147 kg
DIMENSIONI PORTA	329x549 mm

