



QUERCUS IT

QUERCUS EcoDesign



EAN 8426964330205
REF. QUERCUS 33020

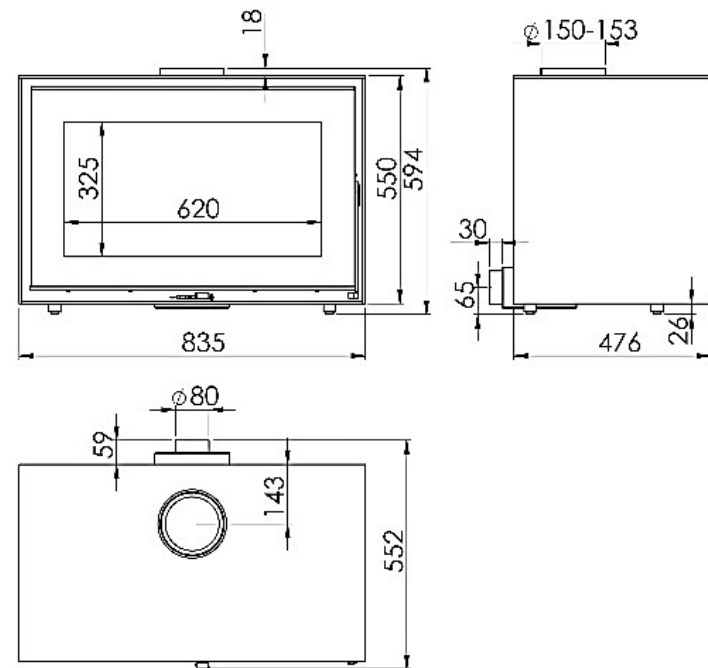

MISURE

DIMENSIONI H X L X P	594x835x552 mm
PESO LORDO /NETTO	177 kg
DIMENSIONI PORTA	620x325 mm
DIAMETRO SCARICO FUMI	Ø 150-153 mm Verticale

CARATTERISTICHE

GRIGLIA IN GHISA	
POTENZA	7,7 KW
RENDIMENTO	85 %
EMISSIONI DI CO	0,050 %
VERNICE ANTICALORE RESISTENTE A	800°C
CRISTALLO IN VETROCERAMICA RESISTENTE A	750°C



PRESA D'ARIA ESTERNA



DOPPIO CORPO IN ACCIAIO DI 6 + 3 MM



FOCOLARE RIVESTITO IN VERMICULITE



PORTA IN VETRO SERIGRAFATO



TRONCHI FINO A 60 CM



230 m³ VOLUME DI RISCALDAMENTO



VETRO SEMPRE PULITO



TRIPLA COMBUSTIONE



A+

