



SEQUOIA ES

SEQUOIA STORE EcoDesign

KUNST



EAN 8426964230406
REF. KUNST 230420

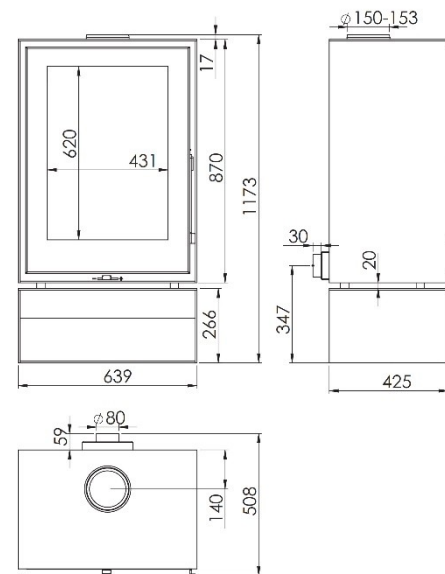

MEDIDAS

MEDIDAS A x A x F	1173x639x508 mm
PESO BRUTO	219 kg
DIMENSIONES PUERTA	431x620 mm
SALIDA DE HUMOS	Ø 150-153 mm Vertical

CARACTERÍSTICAS

PARRILLA DE HIERRO FUNDIDO	
POTENCIA	8,7 KW
RENDIMIENTO	77 %
EMISIÓN DE CO	0,10 %
PINTURA ANTI-CALÓRICA RESISTENTE	800°C
CRISTAL VITROCERÁMICO RESISTENTE	750°C

DISTANCIA MÍNIMA A MATERIALES

COMBUSTIBLES:

Lateral **30 cm** - Trasera **10 cm** - Frontal **130 cm**



TOMA DE AIRE EXTERIOR



DOBLE CUERPO EN ACERO 6 + 3 MM



HOGAR REVESTIDO EN VERMICULITA



TRONCOS HASTA 50 CM



VOLUMEN DE CALEFACCIÓN



SISTEMA DE CRISTAL LIMPIO



TRIPLE COMBUSTIÓN



A

