



WENGUE DE

WENGUE ASYMMETRIC STORE EcoDesign

KUNST



EAN 8426964230321
REF. KUNST 23032

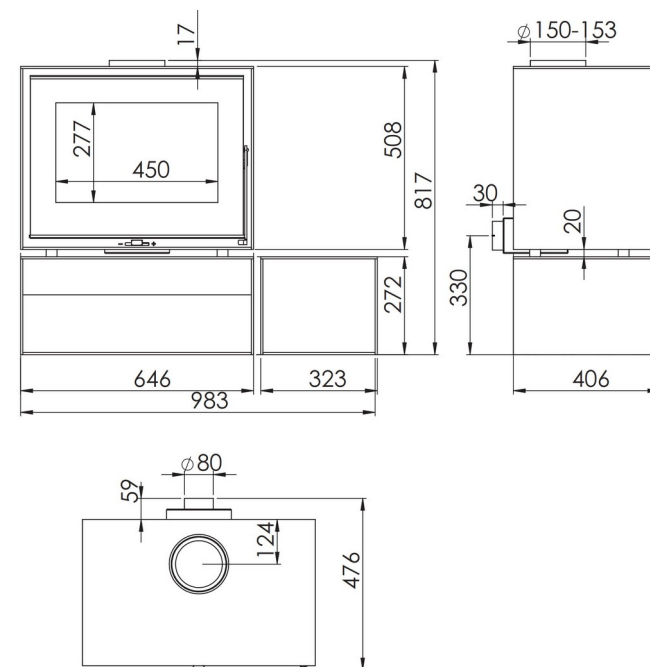

MAßE

MAßE H x B x T **817x983x476 mm**

GEWICHT BRUTTO **158 kg**

MAßE FEUERRAUMTÜR **450x277 mm**

DURCHMESSER DES
ABGASSTUTZENV **Ø 150-153 mm**
Vertikal

ABSTAND ZU ANGRENZENDEN BRENNBAREN
MATERIALIEN:

Seitlich **30 cm** - Vorne **100 cm** - Hinten **10 cm**

EIGENSCHAFTEN

ROST AUS GUSSEISEN

NENNLEISTUNG **5,8 KW**

WIRKUNGSGRAD **80,7 %**

CO - EMISSIONEN **0,10 %**

HITZESCHUTZANSTRICH **800°C**

GLASKERAMIKSCHIEBE **750°C**

HITZEBESTÄNDIG BIS



EXTERNE LUFTZUFUHR



DOPPELBLECHGEHÄUSE
6 + 3 MM



VERMICULIT
AUSKLEIDUNG



BEDRUCKTE
GLASKERAMIK



SCHIETLÄNGE 50 CM



170
m³ **RAUMHEIZVERMÖGEN**



SCHIEBENSÜBLUNG



DREIFACHVERBRENNUNG



A+



flamme
VERTE Le label du chauffage au bois **7★**

