



# WENGUE EcoDesign

# KUNST



EAN 8426964230307  
REF. KUNST 23030

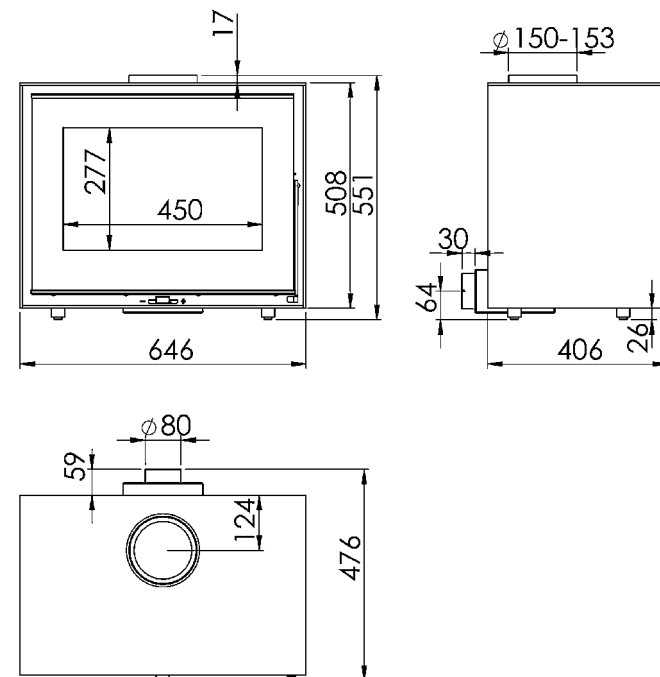

## WYMIARY

WYSOKOŚĆ x SZEROKOŚĆ x GŁĘBOKOŚĆ	<b>551x646x476 mm</b>
WAGA	<b>115 kg</b>
WYMIARY DRZWICZEK	<b>450x277 mm</b>
WYLOT SPALIN	<b>Ø 150-153 mm</b>
ODLEGŁOŚĆ OD SĄSIEDNICH MATERIAŁÓW PALNYCH:	<b>Pionowy</b>
<b>Bok 30 cm - Tył 10 cm - Przód 100 cm</b>	

## CHARAKTERYSTYKA

RUSZT Z ŻELIWA	
MOC NOMINALNA	<b>5,8 KW</b>
SPRAWNOŚĆ	<b>80,7 %</b>
EMISJA CO	<b>0,10 %</b>
FARBA ŻAROODPORNĄ	<b>800°C</b>
SZYBA SZKLANO-CERAMICZNA	<b>750°C</b>



**DOŁOT POWIETRZA Z ZEWNĄTRZ**



**PODWÓJNY KORPUS ZE STALI6 + 3 MM**



**WNĘTRZE WYŁOŻONE WERMIKULITEM**



**SZYBA Z SITODRUKIEM**



**DŁUGOŚĆ POLAN DO 50 CM**



**OGRZEWANA KUBATURA**



**SYSTEM CZYSTA SZYBA**



**SPALANIE TRÓJSTOPNIOWE**



**A+**

