



WILLOW DE

# WILLOW EcoDesign



EAN 8426964230505  
REF. KUNST 23050

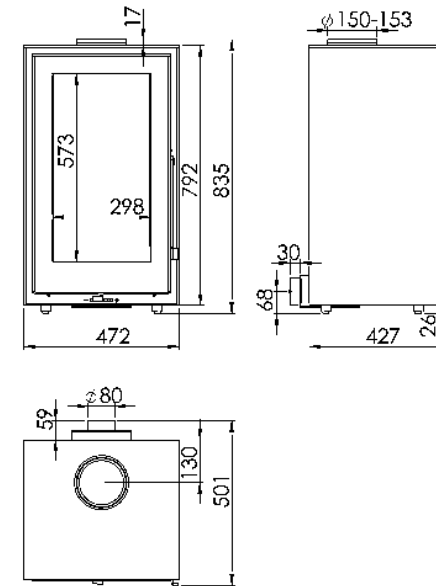

## MABE

MABE H x B x T	<b>835x472x501 mm</b>
GEWICHT BRUTTO	<b>155 kg</b>
MABE FEUERRAUMTÜR	<b>298x573 mm</b>
DURCHMESSER DES ABGASSTUTZENV	<b>Ø 150-153 mm</b> <b>Vertikal</b>

ABSTAND ZU ANGRENZENDEN BRENNBAREN MATERIALIEN:  
Seitlich **20 cm** - Vorne **100 cm** - Hinten **10 cm**

## EIGENSCHAFTEN

ROST AUS GUSSEISEN	
NENNLEISTUNG	<b>8 KW</b>
WIRKUNGSGRAD	<b>80,7 %</b>
CO - EMISSIONEN	<b>0,10%</b>
HITZESCHUTZANSTRICH	<b>800°C</b>
GLASKERAMIKSCHEIBE HITZEBESTÄNDIG BIS	<b>750°C</b>



**EXTERNE LUFTZUFUHR**



**DOPPELBLECHGEHÄUSE  
6 + 3 MM**



**VERMICULIT  
AUSKLEIDUNG**



**BEDRUCKTE  
GLASKERAMIK**



**SCHEITLÄNGE 50 CM**



**240 m³**  
**RAUMHEIZVERMÖGEN**



**SCHEIBENSPÜLUNG**



**DOPPELVERBRENNUNG**



**A+**

