



WILLOW STAND DE

# WILLOW STAND EcoDesign



EAN 8426964230512  
REF. KUNST 23051

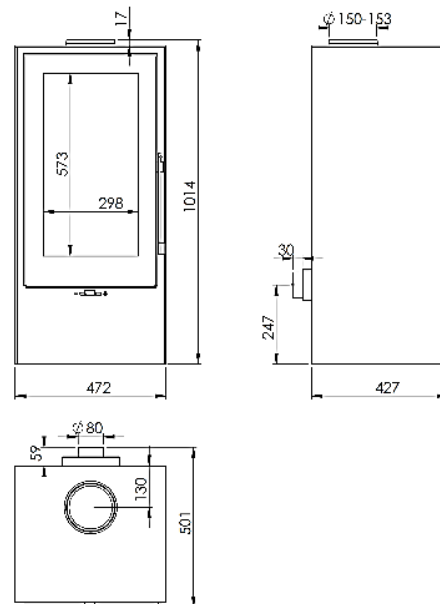

## MAßE

MAßE H x B x T	<b>1014x472x501 mm</b>
GEWICHT BRUTTO	<b>185 kg</b>
MAßE FEUERRAUMTÜR	<b>298x573 mm</b>
DURCHMESSER DES ABGASSTUTZENV	<b>Ø 150-153 mm Vertikal</b>

ABSTAND ZU ANGRENZENDEN BRENNBAREN MATERIALIEN:

Seitlich **20 cm** - Vorne **100 cm** - Hinten **10 cm**

## EIGENSCHAFTEN

ROST AUS GUSSEISEN	
NENNLEISTUNG	<b>8 KW</b>
WIRKUNGSGRAD	<b>80,7 %</b>
CO - EMISSIONEN	<b>0,10%</b>
HITZESCHUTZANSTRICH	<b>800°C</b>
GLASKERAMIKSCHEIBE HITZEBESTÄNDIG BIS	<b>750°C</b>



**EXTERNE LUFTZUFUHR**



**DOPPELBLECHGEHÄUSE 6 + 3 MM**



**VERMICULIT AUSKLEIDUNG**



**BEDRUCKTE GLASKERAMIK**



**SCHEITLÄNGE 50 CM**



**240 m³ RAUMHEIZVERMÖGEN**



**SCHEIBENSPÜLUNG**



**DOPPELVERBRENNUNG**



**A+**

