

H-80 5



CARATTERISTICHE

GRIGLIA IN GHISA	
POTENZA	7,6 KW
RENDIMENTO	87 %
EMISSIONI DI CO	0,05 %
VERNICE ANTICALORE RESISTENTE A	800°C
CRISTALLO IN VETROCERAMICA RESISTENTE A	750°C
DIAMETRO SCARICO FUMI	Ø 150-153 mm Verticale



**PRESA D'ARIA
ESTERNA**



TRONCHI FINO A
50 CM



VOLUME DI
RISCALDAMENTO



PORTA IN VETRO
SERIGRAFATO



VERMICULITE



DOPPIO CORPO IN
ACCIAIO DI 4 + 3 MM



VETRO SEMPRE
PULITO



TRIPLA
COMBUSTIONE

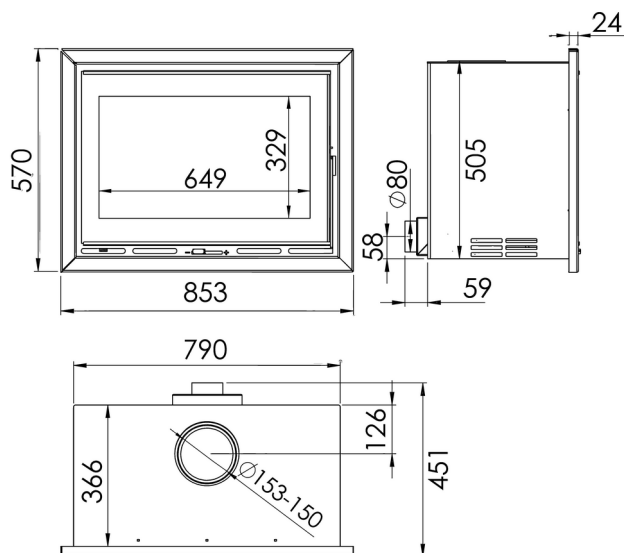

H-80 5

Ref. 33080 / EAN 8426964330809

MISURE

DIMENSIONI H X L X P	570x853x451 mm
PESO LORDO	93 kg
DIMENSIONI PORTA	329x549 mm

